



Grupo Prosegur - Resultados Primer Semestre 2009

Madrid, 30 de julio de 2009



English version
starting page 18



Resumen Ejecutivo

Millones de Euros

 Crecimiento total

Crecimiento

Ventas

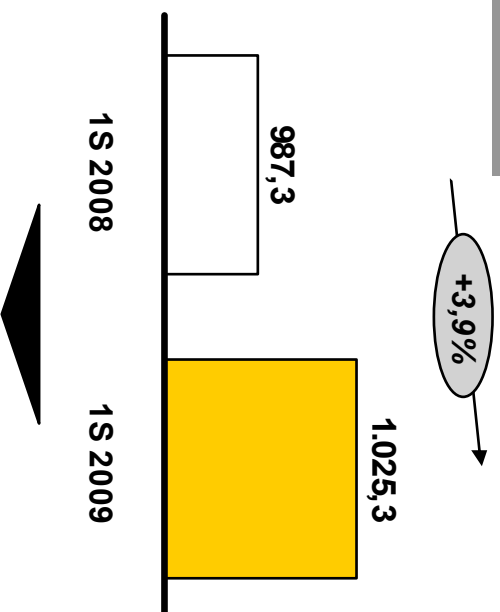

Crecimiento de ventas del 3,9%, siendo el crecimiento orgánico del +1,9%, con el siguiente desglose:
+4,7% crecimiento orgánico puro
-2,7% impacto negativo del tipo de cambio

Rentabilidad

EBITA/ EBIT

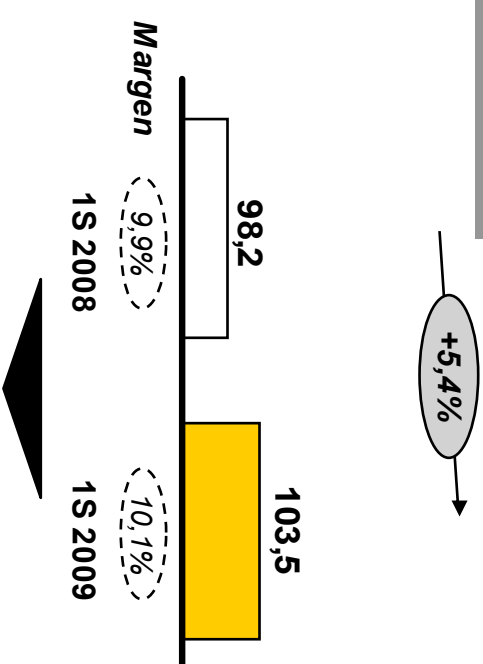

Se mantienen los niveles de rentabilidad alcanzando márgenes de doble dígito, lo que supone una mejora en 0,2 puntos porcentuales respecto al 1S 2008



Detalle de los resultados del primer semestre de 2009

Miliones de Euros

Cuenta de Pérdidas y Ganancias

	1S 2008	1S 2009	Dif.
Ventas	987,3	1.025,3	+3,9%
EBITDA	123,2	132,4	+7,5%
<i>Margen</i>	<i>12,5%</i>	<i>12,9%</i>	
Depreciación	-25,0	-28,9	
EBIT	98,2	103,5	+5,4%
<i>Margen</i>	<i>9,9%</i>	<i>10,1%</i>	
Resultados Financieros	-7,0	-7,0	
Resultado antes de impuestos	91,1	96,5	+5,9%
<i>Margen</i>	<i>9,2%</i>	<i>9,4%</i>	
Impuestos	-29,2	-32,2	
Resultado del ejercicio	62,0	64,3	+3,8%
Intereses Minoritarios	0,2	0,4	
Resultado Neto Consolidado	62,1	64,7	+4,2%
<i>Margen</i>	<i>6,3%</i>	<i>6,3%</i>	



Análisis de las ventas

Millones de Euros

Cuenta de Pérdidas y Ganancias

	1S 2008	1S 2009	Dif.
Ventas	987,3	1.025,3	+3,9%
EBITDA	123,2	132,4	+7,5%
Margen	12,5%	12,9%	
Depreciación	-25,0	-28,9	
EBIT	98,2	103,5	+5,4%
Margen	9,9%	10,1%	
Resultados Financieros	-7,0	-7,0	
Resultado antes de impuestos	91,1	96,5	+5,9%
Margen	9,2%	9,4%	
Impuestos	-29,2	-32,2	
Resultado del ejercicio	62,0	64,3	+3,8%
Intereses Minoritarios	0,2	0,4	
Resultado Neto Consolidado	62,1	64,7	+4,2%
Margen	6,3%	6,3%	

Detalle del crecimiento de las Ventas

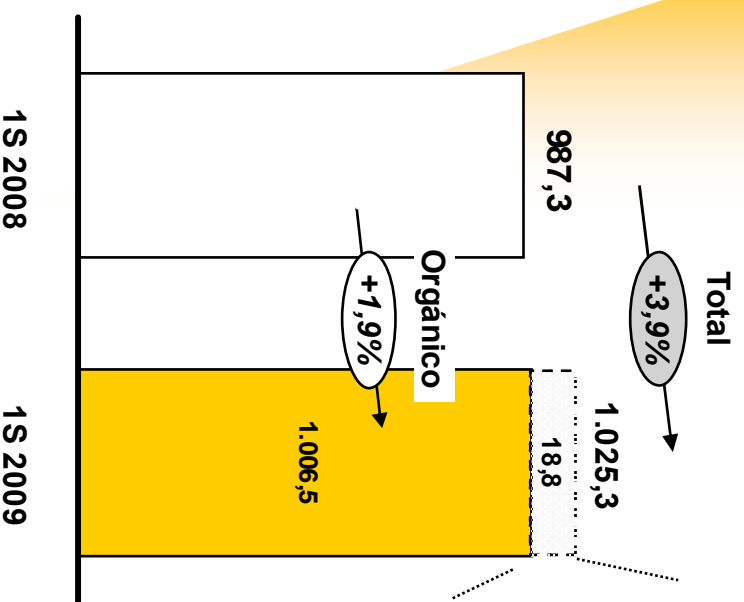

Ventas por el efecto de las adquisiciones:

- Valtis – Francia
- Giasa – Argentina
- Ryes - México
- Setha – Brasil
- Centuria – Brasil
- Telemergenda y Punta Systems – Prosegur Activa

El crecimiento orgánico puro es del +4,7%, mientras que el tipo de cambio ha tenido un impacto negativo de -2,7% respecto al mismo período de 2008



Análisis de los márgenes operativos

Miliones de Euros

Cuenta de Pérdidas y Ganancias

	1S 2008	1S 2009	Dif.
Ventas	987,3	1.025,3	+3,9%
EBITDA	123,2	132,4	+7,5%
Margen	12,5%	12,9%	
Depreciación	-25,0	-28,9	
EBIT	98,2	103,5	+5,4%
Margen	9,9%	10,1%	
Resultados Financieros	-7,0	-7,0	
Resultado antes de impuestos	91,1	96,5	+5,9%
Margen	9,2%	9,4%	
Impuestos	-29,2	-32,2	
Resultado del ejercicio	62,0	64,3	+3,8%
Intereses Minoritarios	0,2	0,4	
Resultado Neto Consolidado	62,1	64,7	+4,2%
Margen	6,3%	6,3%	

Detalle de la evolución de los márgenes EBITA

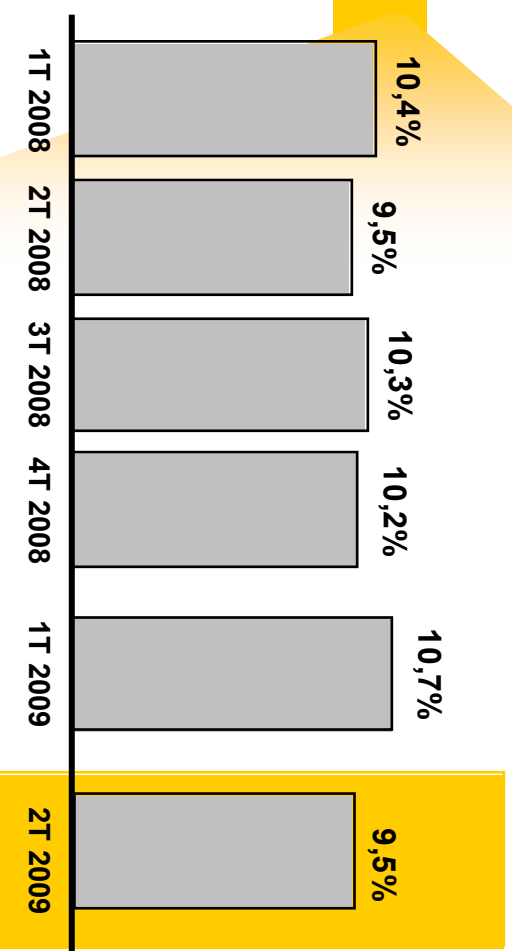

Análisis de los resultados financieros y fiscales

Miliones de Euros

Cuenta de Pérdidas y Ganancias

	1S 2008	1S 2009	Dif.
Ventas	987,3	1.025,3	+3,9%
EBITDA	123,2	132,4	+7,5%
Margen	12,5%	12,9%	
Depreciación	-25,0	-28,9	
EBIT	98,2	103,5	+5,4%
Margen	9,9%	10,1%	
Resultados Financieros	-7,0	-7,0	
Resultado antes de impuestos	91,1	96,5	+5,9%
Margen	9,2%	9,4%	
Impuestos	-29,2	-32,2	
Resultado del ejercicio	62,0	64,3	+3,8%
Intereses Minoritarios	0,2	0,4	
Resultado Neto Consolidado	62,1	64,7	+4,2%
Margen	6,3%	6,3%	

Detalle de los resultados Financieros

- El resultado financiero/gasto financiero neto del Grupo en el primer semestre de 2009 fue de 7,0 millones de euros, al igual que en el primer semestre de 2008. El desglose de los gastos financieros es el siguiente:
 - Los gastos financieros netos por intereses fueron de 6,2 millones de euros frente a los 10,1 millones de euros del primer semestre del ejercicio anterior, lo que representa una disminución de 3,9 millones. Dicha disminución se debe principalmente al descenso en los tipos de interés
 - El Grupo tiene contratados instrumentos financieros derivados con el fin de neutralizar los ajustes en tipos de cambio o las variaciones en los tipos de interés. El efecto neto en los resultados financieros del primer semestre de 2009 ha sido de - 0,8 millones de euros

Detalle de los impuestos

- La carga fiscal ha aumentado en 1,4 puntos porcentuales, pasando del 32,0% en el 1S 2008 al 33,4% del presente ejercicio



Balance de situación abreviado

Millones de Euros

	<u>31/12/2008</u>	<u>30/06/2009</u>
Activo no corriente	710,5	781,8
Inmovilizado material	281,7	310,0
Fondo de comercio	270,5	304,3
Activos intangibles	75,9	79,5
Activos financieros no corrientes	34,5	35,7
Otros activos no corrientes	47,9	52,3
Activo corriente	732,0	703,1
Existencias	24,4	26,3
Deudores	492,8	523,1
Otros activos corrientes	0,4	0,4
Instrumentos financieros derivados	7,3	-
Tesorería y otros activos financieros	207,1	153,3
ACTIVO	1.442,5	1.484,9
Patrimonio Neto	424,6	423,0
Capital social	37,0	37,0
Acciones propias	-29,4	-40,2
Ganancias acumuladas y otras reservas	416,0	425,6
Intereses minoritarios	1,0	0,6
Pasivo no corriente	403,5	379,9
Deudas con entidades de crédito	222,5	169,1
Instrumentos financieros derivados	0,3	0,8
Otros pasivos no corrientes	180,7	210,0
Pasivo corriente	614,4	682,0
Deudas con entidades de crédito	133,1	153,8
Instrumentos financieros derivados	1,5	1,2
Acreedores comerciales y otras cuentas a pagar	387,0	446,8
Otros pasivos corrientes	92,8	80,2
PATRIMONIO NETO Y PASIVO	1.442,5	1.484,9



Inversiones y Deuda Neta

Millones de Euros

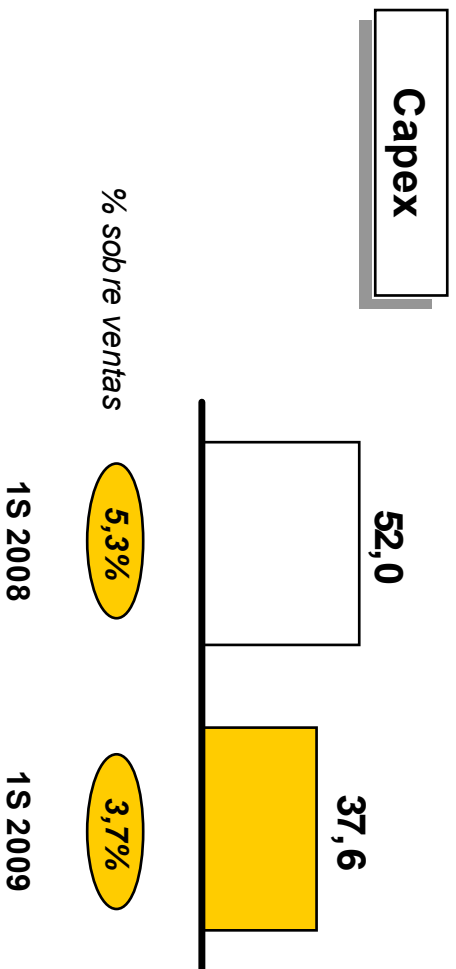

Se mantiene la fuerte política inversora de la compañía, con el objetivo de la búsqueda de la excelencia operativa y la innovación continua

Nota: La cifra de Capex del 1S2008 incluye inversiones extraordinarias de € 12 millones en inmuebles/ terrenos

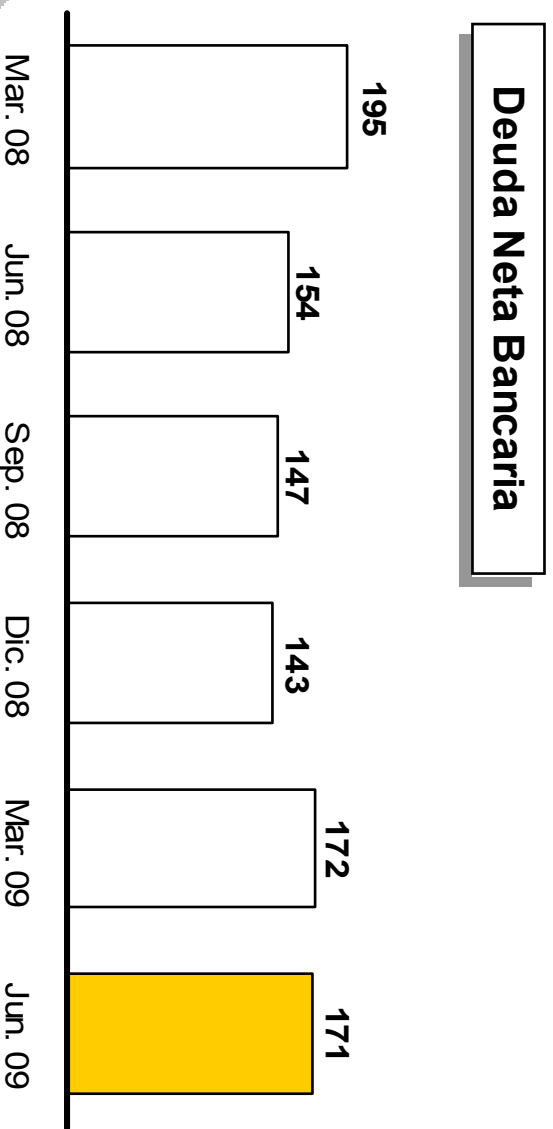

La deuda neta de la compañía alcanzó los € 171 millones. Dicho valor incluye el efecto de la titulización de la cartera de clientes de España y Portugal que en el 1S de 2009 ascendió a € 137 millones



Desglose de los resultados del Grupo por área de negocio

Millones de Euros

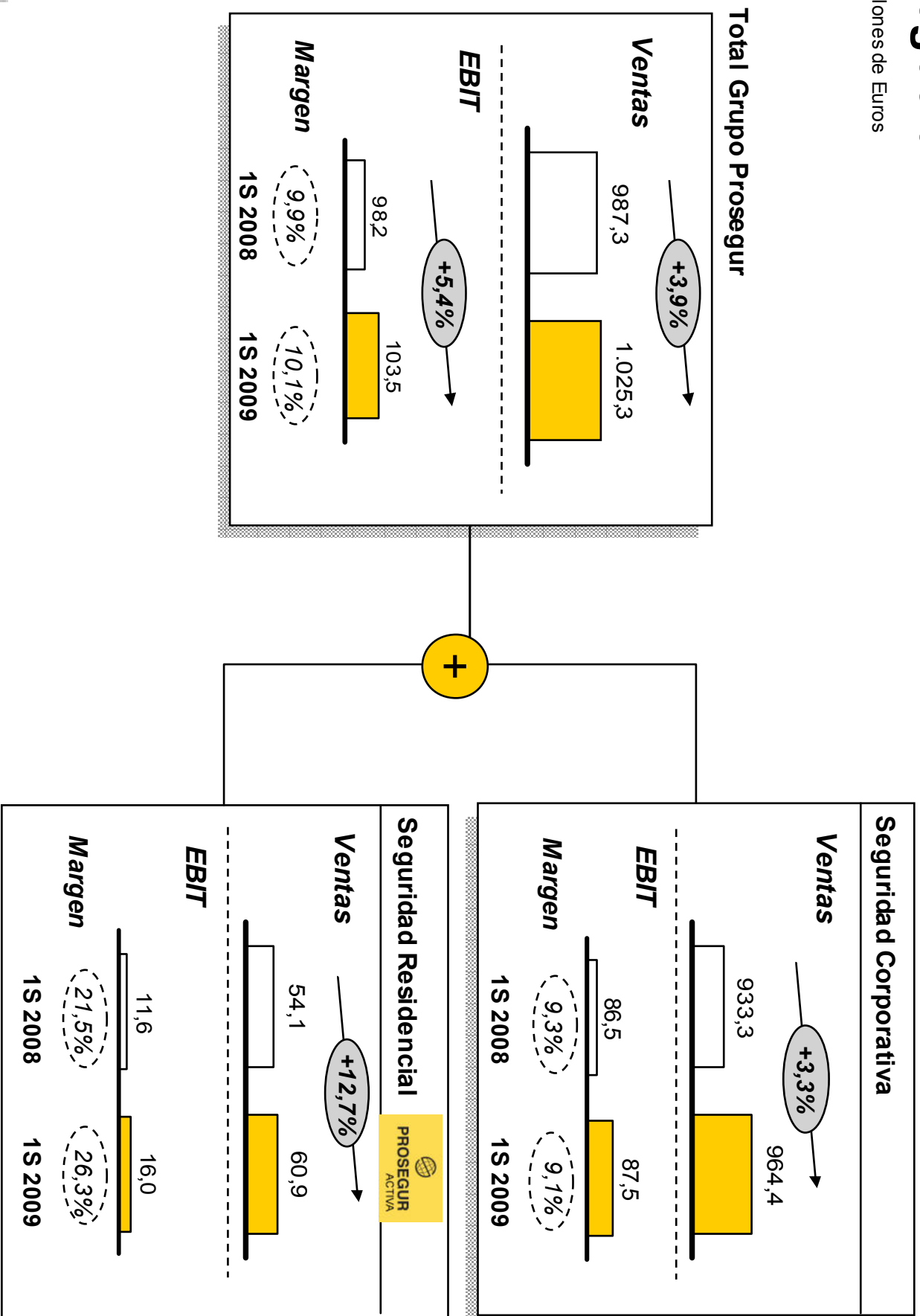

Seguridad Corporativa



Desglose de los resultados de Seguridad Corporativa

Millones de Euros

Total Seguridad Corporativa

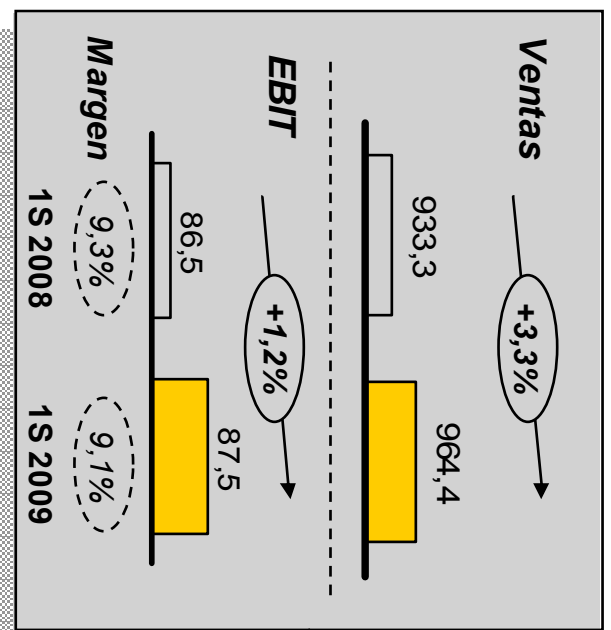

+

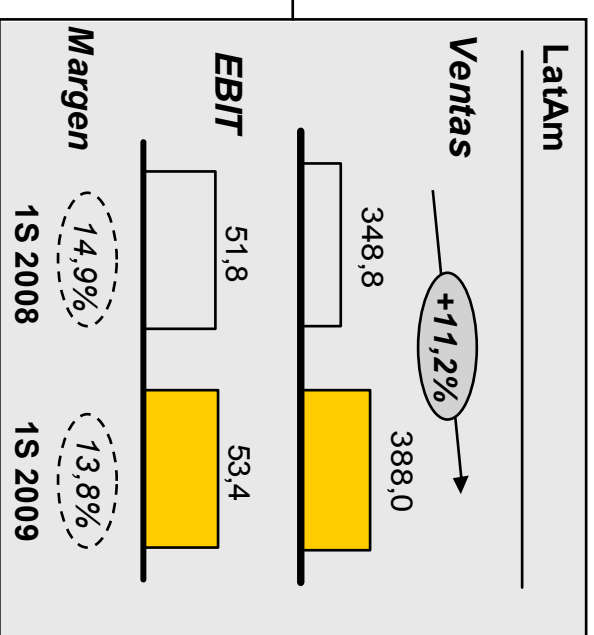
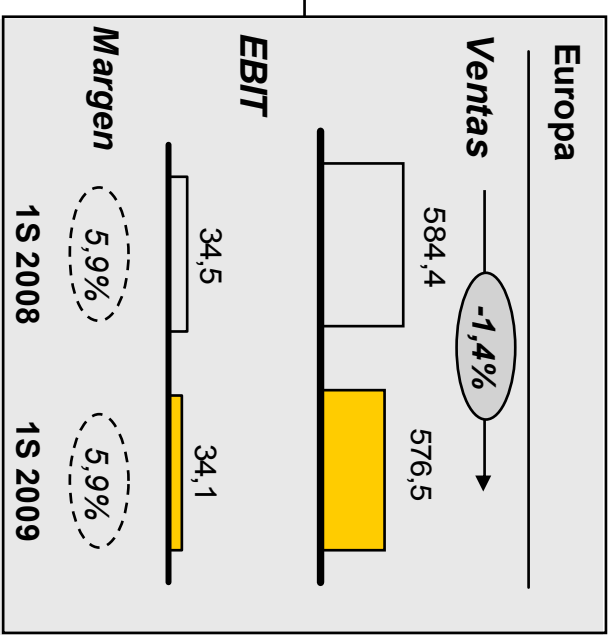

Seguridad Corporativa: Resultados de Europa

Ventas totales. Millones de Euros

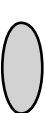
 Crecimiento total

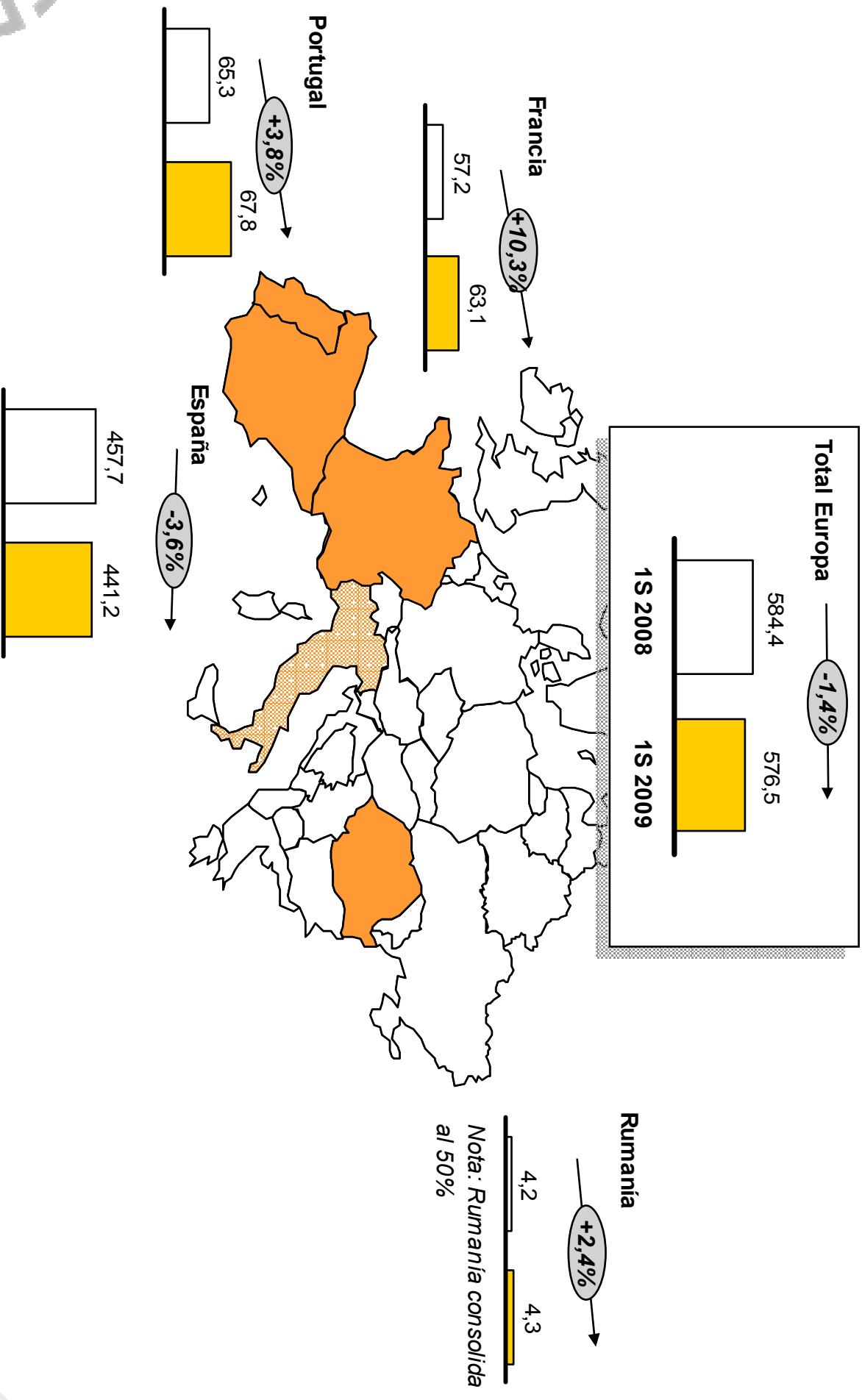

Seguridad Corporativa: Resultados de Latinoamérica



Ventas totales. Millones de Euros

Crecimiento total

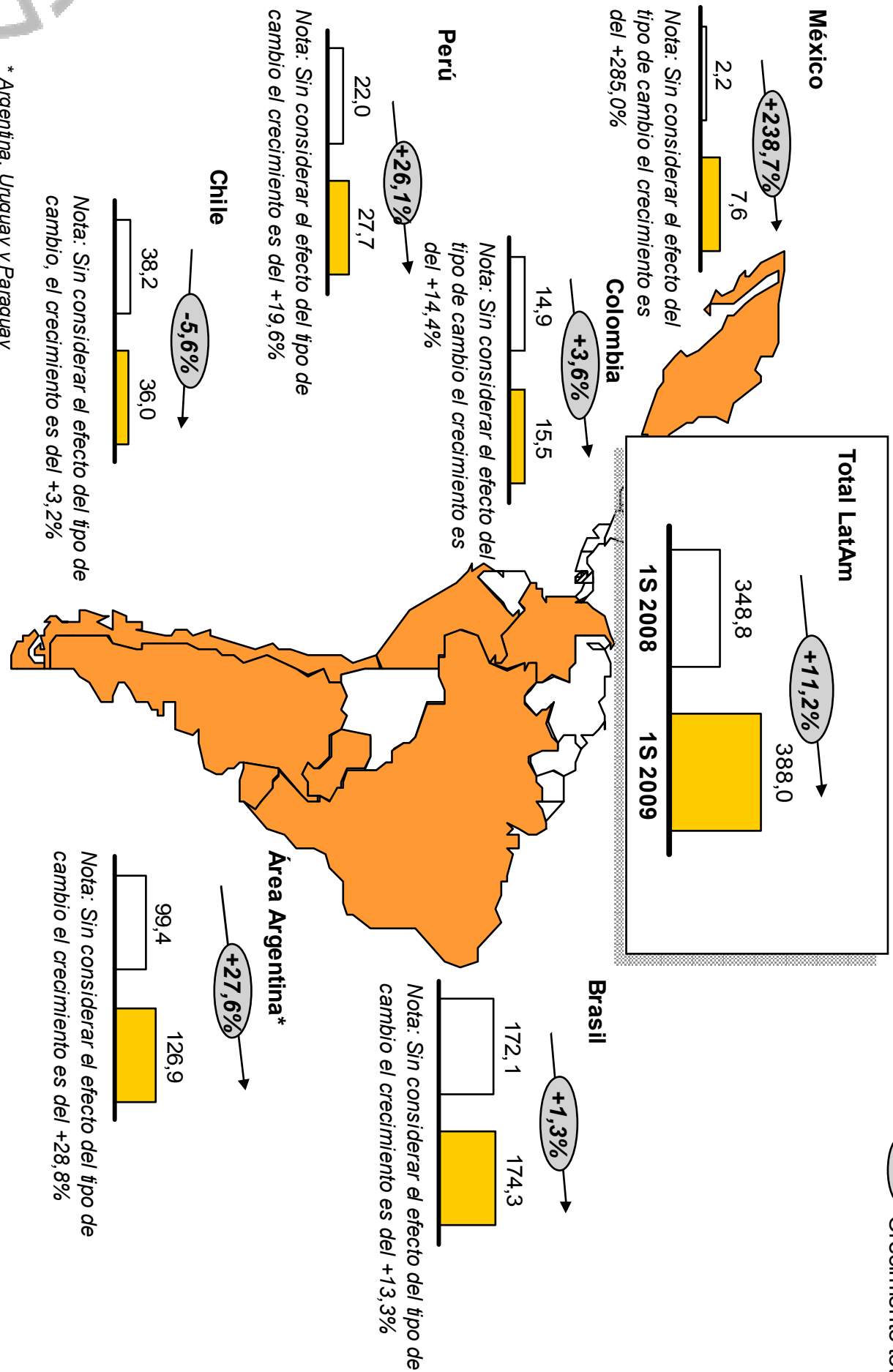

* Argentina, Uruguay y Paraguay

Hechos del periodo a destacar

Europa

- A nivel ventas, en el primer semestre del año ha descendido un 1,4% la cifra de negocio en relación con el 1 S de 2008. Esto es debido a:
 - Leve deterioro de los volúmenes en España, sin que dicho deterioro haya sido significativo en ninguno de los negocios en particular
 - Buena evolución en Portugal y Francia, que incluye el efecto positivo de Valtis
 - Mejora de la cifra de negocio en Rumania en 0,1M€
- Los márgenes se han mantenido estables en todos los países de la región

LatAm

- Aún después del fuerte impacto negativo del tipo de cambio en Brasil, Argentina, Chile y Colombia, la región ha alcanzado un crecimiento en ventas de doble dígito
- A nivel de márgenes de negocio, se ha producido un leve deterioro en la región. El mayor volumen de negocio en México ha venido acompañado de un mayor resultado negativo

Adquisiciones realizadas en el Primer Semestre de 2009 y Julio 2009 (sólo Seguridad Corporativa)

- En el marco de la estrategia del Grupo de combinar crecimiento orgánico con inorgánico, en el primer semestre del año y en julio de 2009 se han realizado una serie de adquisiciones en línea con los objetivos de crecimiento de Prosegur:

Compañía	País	Fecha de adquisición	Actividad	Facturación	Nº Empleados
Setha	Brasil	Ene. 2009	Tecnología: sistemas electrónicos de seguridad	~ 9M €	100
Centuria	Brasil (Estado de Espíritu Santo)	Ene. 2009	Prestación de servicios de Vigilancia	~ 3,3M €	580
Glasa	Argentina	Ene. 2009	Tecnología: monitoreo de alarmas corporativas (sector bancario)	~ 7,8M €	127
Valtis	Francia	Feb. 2009	Logística de Valores y Gestión de Efectivo	~ 16M €	250
Orus, S.A	Perú	Jun. 2009	Prestación de servicios de Vigilancia	~ 31M €	4.400
Segmatic	Chile	Jun. 2009	Tecnología: protección contra incendios	~ 5M €	85
Norsergel	Brasil	Julio 2009 (no consolidada en el semestre)	Servicios de Logística de Valores, Gestión de Efectivo y Vigilancia	~ 81M €	6.700



Seguridad Residencial



Análisis Resultados Seguridad Residencial

Millones de euros

 Crecimiento total

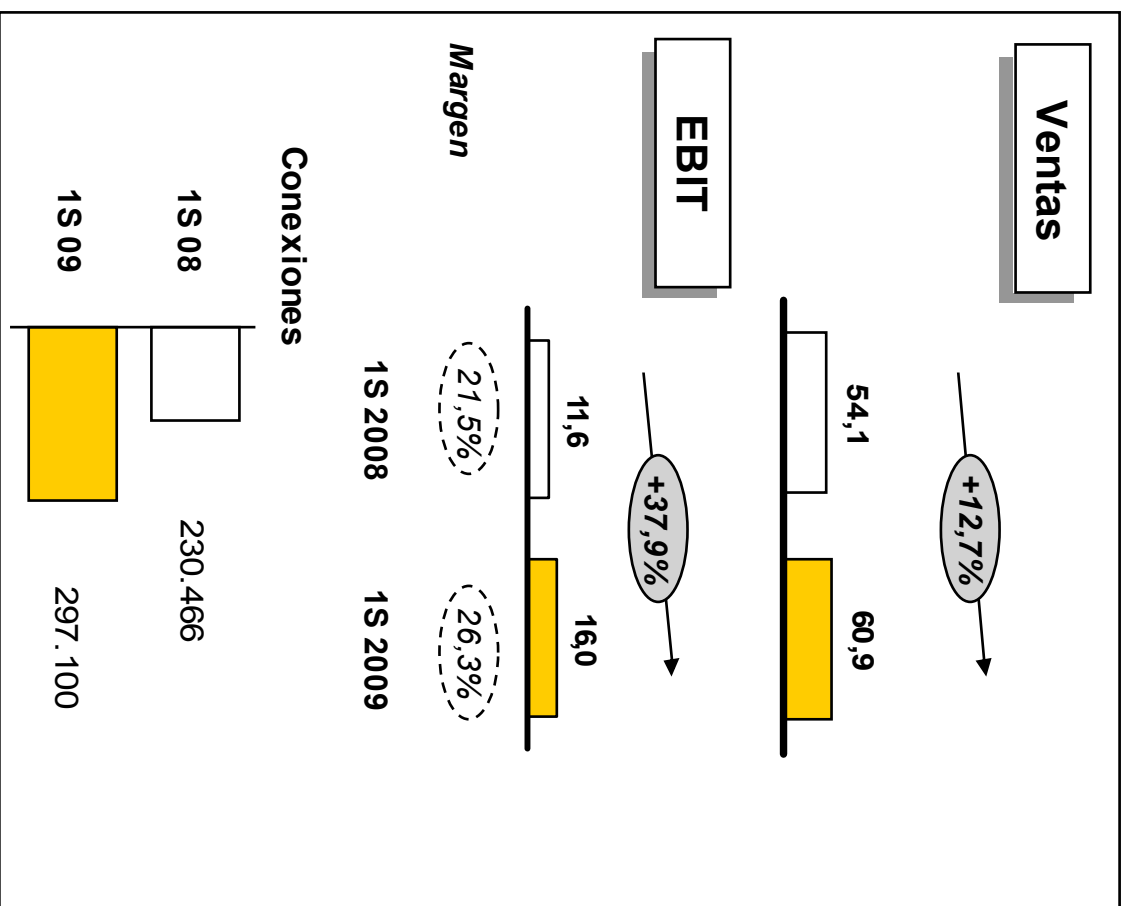

Hechos relevantes del periodo

- Continúa la tendencia de fuerte crecimiento del negocio de Prosegur Activa tanto en:
 - Conexiones y Ventas, con el efecto positivo de la incorporación de los negocios de Telemergencia en Chile y Punta Systems en Uruguay,
 - Como en márgenes EBIT, por la estrategia de combinar crecimiento sostenido con alta rentabilidad
- Con fecha 24 de junio de 2009 se adquirió en Perú el 100% de Orus Seguridad Electrónica, S.A. Esta adquisición implica que en la actualidad Prosegur Activa esté presente en 6 países





Grupo Prosegur – Results 1st Half 2009

Madrid, 30th July 2009



Executive summary

In Million Euros

 Total Growth

Growth

Sales

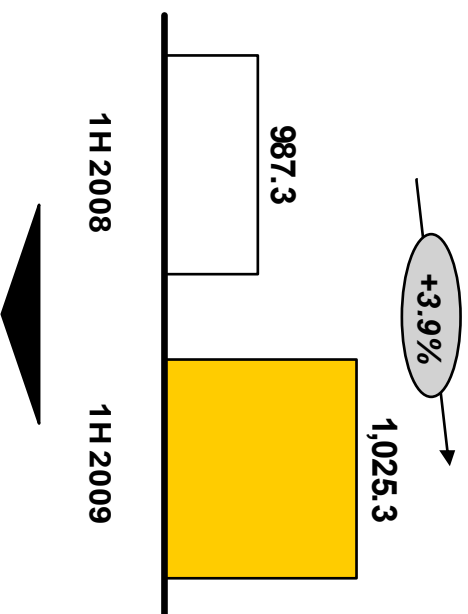

Strong growth trend, mainly due to the organic growth: (+1.9%) with the following breakdown :
+4.7% "Pure" organic growth
- 2.7% due to negative impact of exchange rates

Profitability

EBIT/ EBIT

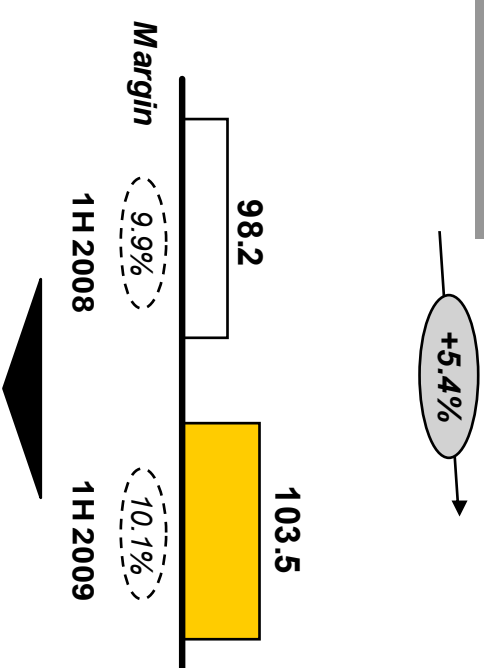

Maintaining levels of profitability achieving double-digit margins. The EBITA margin has improved by 0.2 percentage points compared to 1H 2008



Overview of Gruppo Prosegur 1H 2009 financial results

In Million Euros

Profit and Loss Account

	1H 2008	1H 2009	Var.
Sales	987.3	1,025.3	+3.9%
EBITDA	123.2	132.4	+7.5%
% Margin	12.5%	12.9%	
Depredation	-25.0	-28.9	
EBIT	98.2	103.5	+5.4%
% Margin	9.9%	10.1%	
Financial Results	-7.0	-7.0	
Profit Before Taxes	91.1	96.5	+5.9%
% Margin	9.2%	9.4%	
Taxes	-29.2	-32.2	
Net Profit	62.0	64.3	+3.8%
Minority Interests	0.2	0.4	
Net Consolidated Profit	62.1	64.7	+4.2%
% Margin	6.3%	6.3%	



Sales analysis

In Million Euros

Profit and Loss Account

	1H 2008	1H 2009	Var.
Sales	987.3	1,025.3	+3.9%
EBITDA	123.2	132.4	+7.5%
% Margin	12.5%	12.9%	
Depreciation	-25.0	-28.9	
EBIT	98.2	103.5	+5.4%
% Margin	9.9%	10.1%	
Financial Results	-7.0	-7.0	
Profit Before Taxes	91.1	96.5	+5.9%
% Margin	9.2%	9.4%	
Taxes	-29.2	-32.2	
Net Profit	62.0	64.3	+3.8%
Minority Interests	0.2	0.4	
Net Consolidated Profit	62.1	64.7	+4.2%
% Margin	6.3%	6.3%	

Breakdown of sales growth

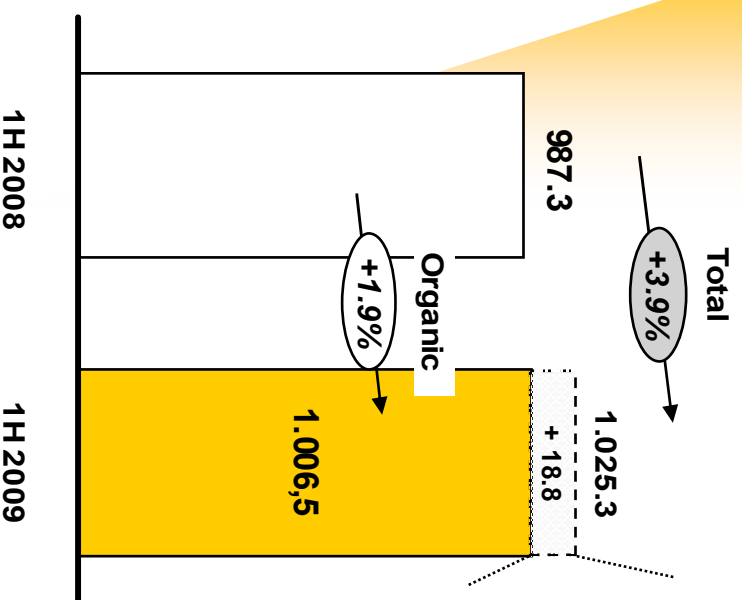

Sales from acquisitions:

- Valits – France
- Giasa – Argentina
- Ryes – Mexico
- Setha – Brazil
- Centuria – Brazil
- Telemergencia and Punta Systems – Prosegur Activa

The “pure” organic growth was +4.7%, having the exchanges rates a negative impact of -2.7%



Operating margin analysis

In Million Euros

Profit and Loss Account

	1H 2008	1H 2009	Var.
Sales	987.3	1,025.3	+3.9%
EBITDA	123.2	132.4	+7.5%
% Margin	12.5%	12.9%	
Depreciation	-25.0	-28.9	
EBIT	98.2	103.5	+5.4%
% Margin	9.9%	10.1%	
Financial Results	-7.0	-7.0	
Profit Before Taxes	91.1	96.5	+5.9%
% Margin	9.2%	9.4%	
Taxes	-29.2	-32.2	
Net Profit	62.0	64.3	+3.8%
Minority Interests	0.2	0.4	
Net Consolidated Profit	62.1	64.7	+4.2%
% Margin	6.3%	6.3%	

Evolution of EBITA margin

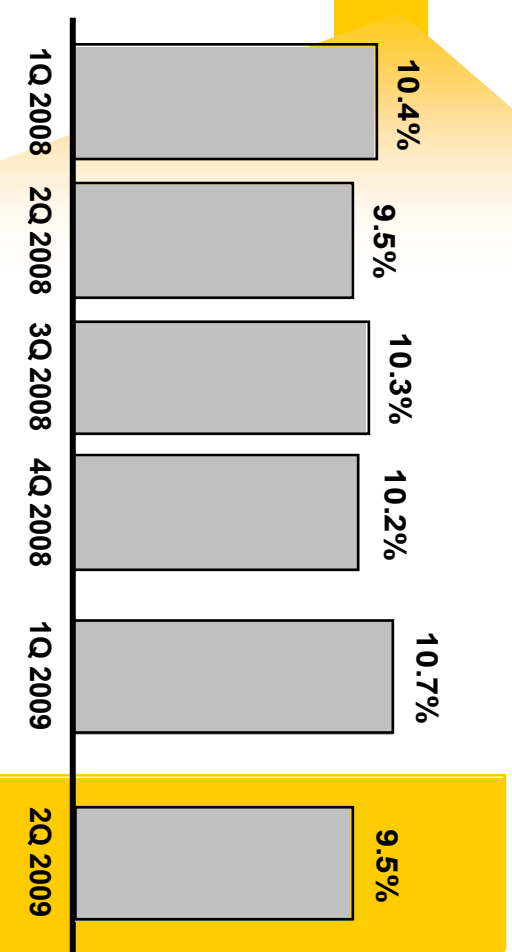

Financial and Tax results analysis

In Million Euros

Profit and Loss Account

	1H 2008	1H 2009	Var.
Sales	987.3	1,025.3	+3.9%
EBITDA	123.2	132.4	+7.5%
% Margin	12.5%	12.9%	
Depreciation	-25.0	-28.9	
EBIT	98.2	103.5	+5.4%
% Margin	9.9%	10.1%	
Financial Results	-7.0	-7.0	
Profit Before Taxes	91.1	96.5	+5.9%
% Margin	9.2%	9.4%	
Taxes	-29.2	-32.2	
Net Profit	62.0	64.3	+3.8%
Minority Interests	0.2	0.4	
Net Consolidated Profit	62.1	64.7	+4.2%
% Margin	6.3%	6.3%	

Overview of Financial Results

In the first half of 2009, the Group's net financial expenses reached the amount of € 7.0 million, the same as in the first half of 2008. The financial expenses breakdown is as follows:

- The pure financial expenses reached € 6.2 million (vs. € 10.1 million) which implies a decrease of € 3.9 million compared to 1H2008. This decrease is due to the reduction of the average cost of debt during the first half of 2009
- The adjustments to foreign exchange rates and derivatives contracted by the Group in order to neutralize the impact of fluctuations in exchange rates and interest rates had a total net impact of € -0.8 million

Overview of tax charges

- Tax rates have increased by 1.4 percentage points, moving from 32.0% in 1H 2008 to 33.4% in the current financial year



Abridged balance sheet

In Million Euros

	31/12/2008	30/06/2009
Non Current Assets	710.5	781.8
Tangible fixed assets	281.7	310.0
Goodwill	270.5	304.3
Intangible assets	75.9	79.5
Available-for-sale financial assets and others	34.5	35.7
Assets due to deferred tax	47.9	52.3
Current Assets	732.0	703.1
Inventories	24.4	26.3
Customers and other receivables	492.8	523.1
Available-for-sale non current assets	0.4	0.4
Derivative financial instruments	7.3	-
Cash equivalents and other financial assets	207.1	153.3
ASSETS	1,442.5	1,484.9
Net Equity	424.6	423.0
Share capital	37.0	37.0
Treasury share	-29.4	-40.2
Accumulated difference and others reserves	416.0	425.6
Minority interests	1.0	0.6
Non Current Assets	403.5	379.9
Long term bank loans	222.5	169.1
Derivative financial instruments	0.3	0.8
Other non current assets	180.7	210.0
Current Liabilities	614.4	682.0
Short term bank loans	133.1	153.8
Derivative financial instruments	1.5	1.2
Suppliers and other payables	387.0	446.8
Other current liabilities	92.8	80.2
TOTAL NET EQUITY AND LIABILITIES	1,442.5	1,484.9



Investments and Net Banking Debt evolution

In Million Euros

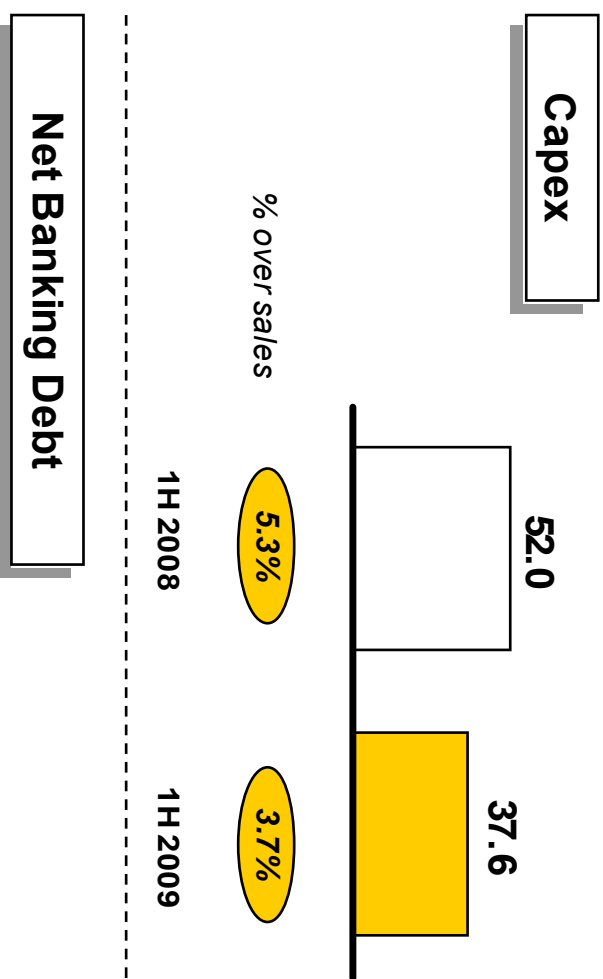

Maintenance of a strong investment policy with the objective of searching for operational excellence and continuous innovation

Note: The 1H2008 Capex figure includes € 12 million of extraordinary investments in land /building

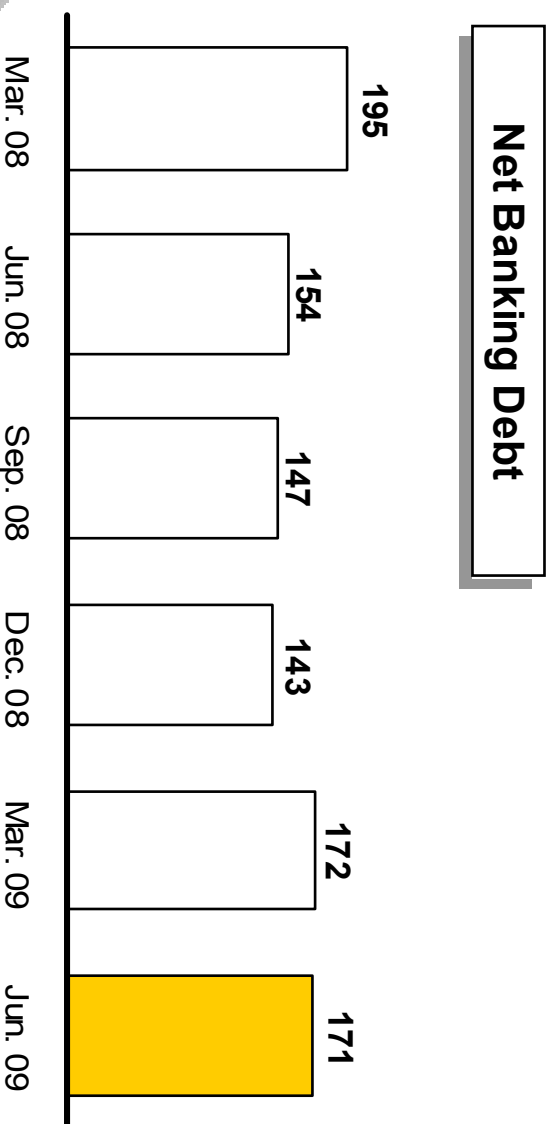

The company's net banking debt amounted € 171 million. This value includes the effect of the securitization of the client portfolio in Spain and Portugal: € 137 million in 1H2009



Breakdown of Grupo Prosegur results by business areas

In Million Euros

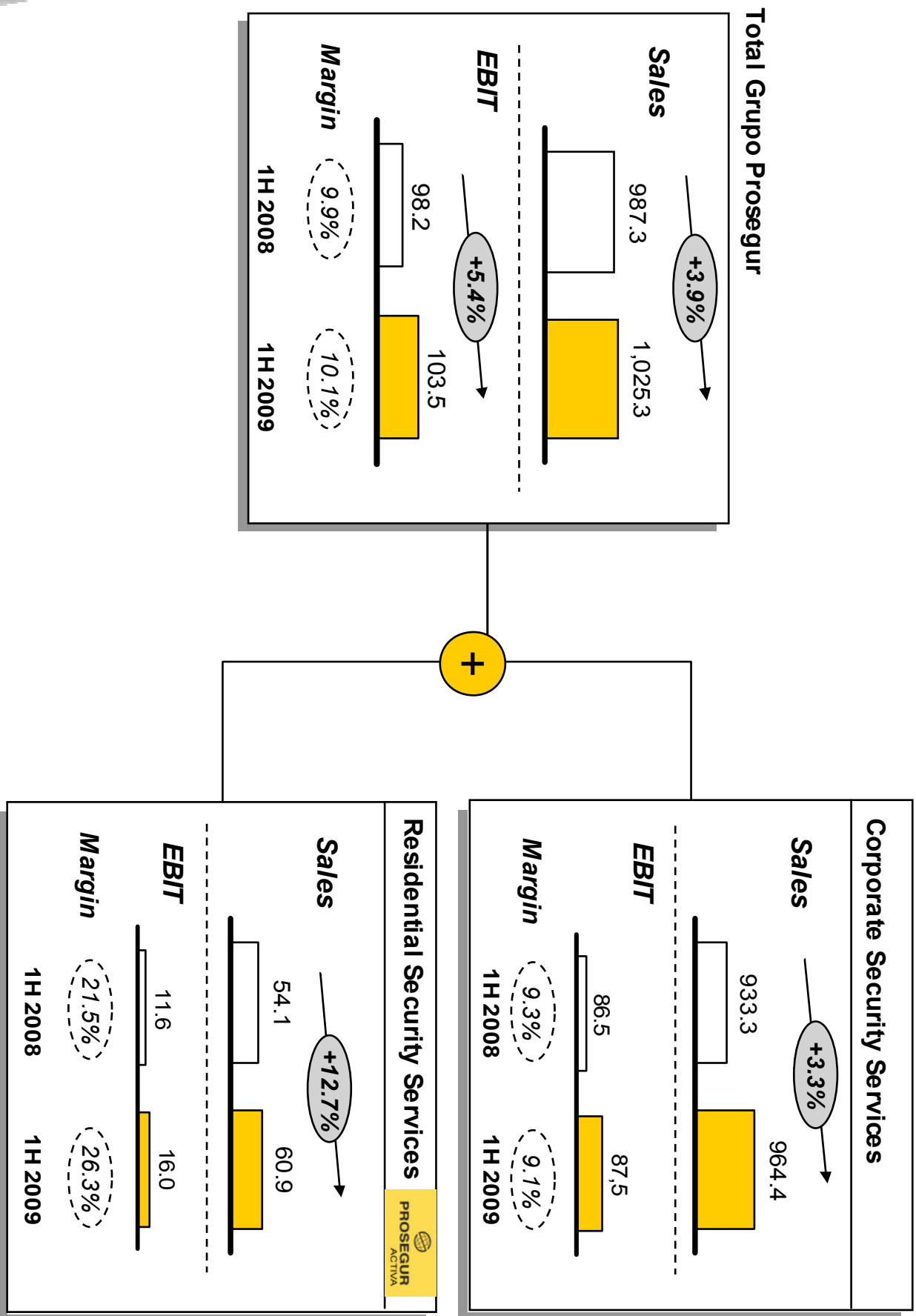

Corporate Security Services



Breakdown of 1H 2009 Corporate Security Services results by geographic regions

In Million Euros

Total 1H 2009 Corporate Security Services

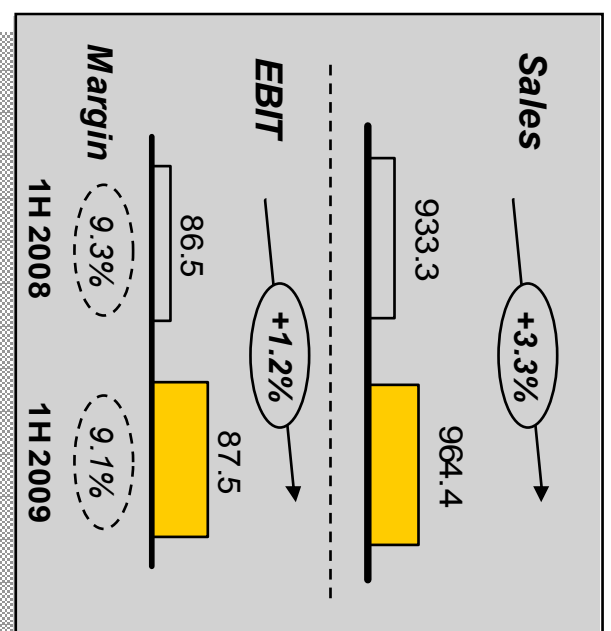

+

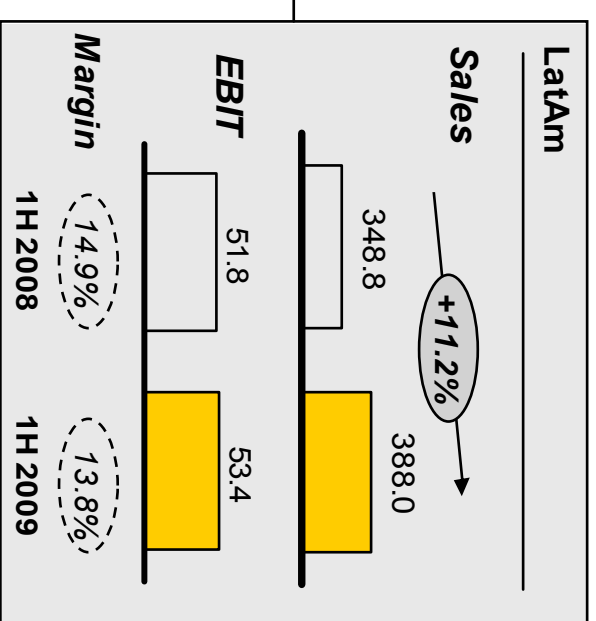
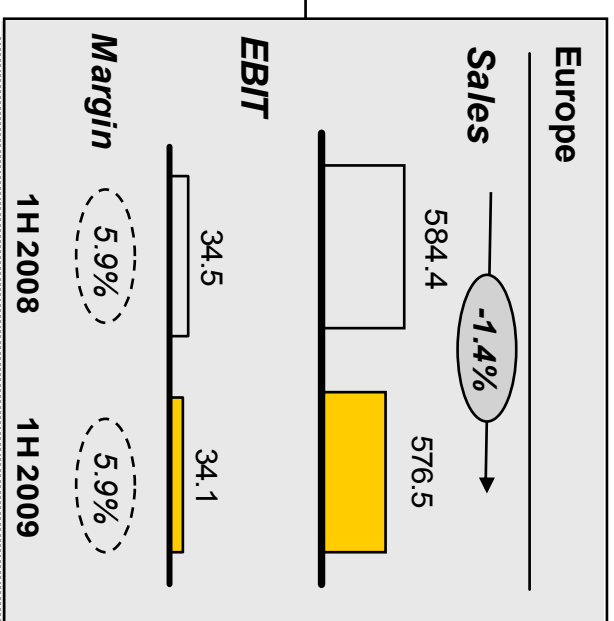

Corporate Security Services: European Revenues

Total sales. In Million Euros

 Total Growth

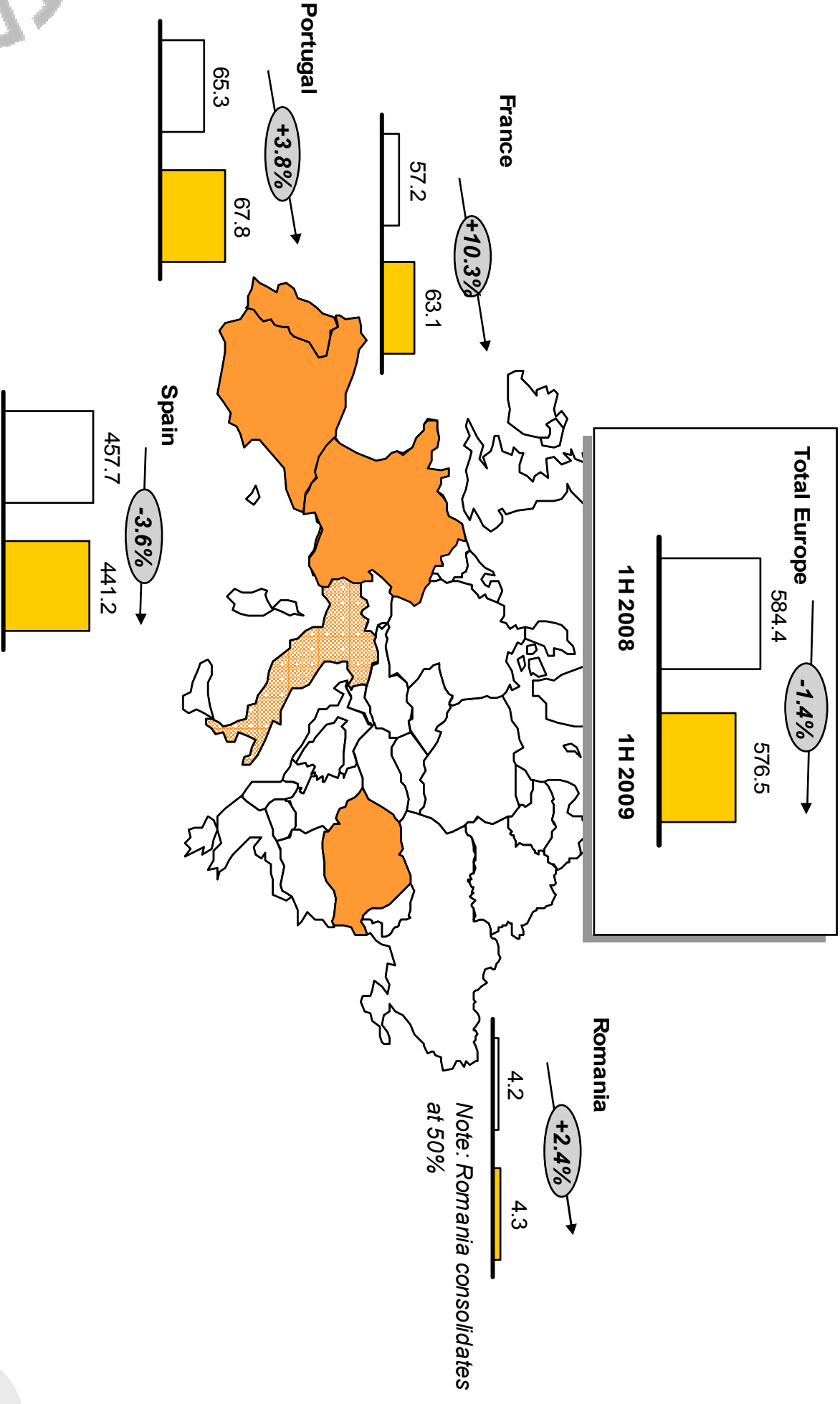

Corporate Security Services: Latin-American Revenues



Total sales: In Million Euros

Total Growth

Mexico

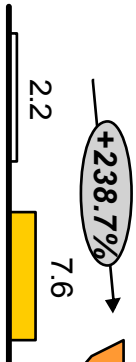

Note: The growth is +285% without considering the exchange rate effect

Total LatAm

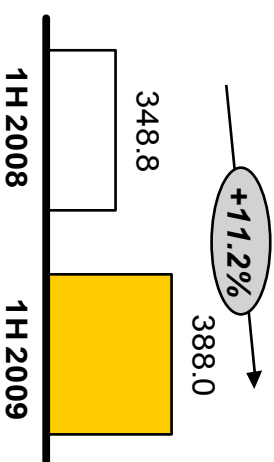

Colombia



Note: The growth is +14.4% without considering the exchange rate effect

Peru

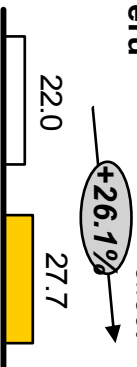

Note: The growth is +19.6% without considering the exchange rate effect

Chile

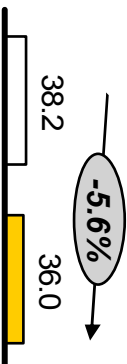

Note: The growth is +3.2% without considering the exchange rate effect

Brazil

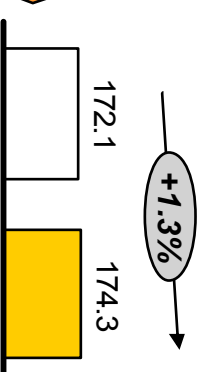

Note: The growth is +13.3% without considering the exchange rate effect

Argentina Area*

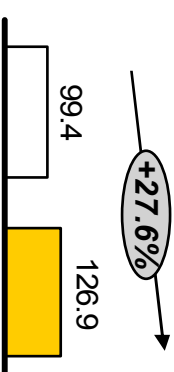

Note: The growth is +28.8% without considering the exchange rate effect

* Argentina, Uruguay and Paraguay

1H Highlights of the period

Europe

- Region sales have dropped 1.4% in 1H 2009, compared to those from H1 2008. This is due to:
 - Slight deterioration of volumes in Spain, not significant in any of the particular businesses
 - Good performance in Portugal and France, which includes the positive effect of Valtis
 - Revenues increase in Romania by € 0.1 million
- Margins have been stable in all countries across the region

LatAm

- Even after the strong negative impact of the exchange rates in Brazil, Argentina, Chile and Colombia, the region has achieved a double-digit growth in sales
- 1H 2009 margins have shown a slight deterioration in the region. The higher turnover of business in Mexico has been accompanied by higher negative results

Acquisitions in the First Half of 2009 and July 2009 (only Corporate Security Services)

- Within the Group's strategy of combining organic and inorganic growth, a number of acquisitions has been executed in 1H 2009 and July 2009 which strengthen our presence in the current markets

Company	Country	Date of Acquisition	Activity	Revenues	Nº Employees
Setha	Brazil	Jan. 2009	Electronic Systems	~ 9M €	100
Centuria	Brazil (State of Espírito Santo)	Jan. 2009	Guarding Services	~ 3.3M €	580
Giasa	Argentina	Jan. 2009	Corporate Alarms Monitoring (banking sector)	~ 7.8M €	127
Valtis	France	Feb. 2009	Valuables Transport and Cash Management	~ 16M €	250
Orus, S.A	Peru	Jun. 2009	Guarding Services	~ 31M €	4,400
Segmatic	Chile	Jun. 2009	Electronic Systems: fire protection	~ 5M €	85
Norsergel	Brazil (not consolidated in 1H 2009)	Jul. 2009	Valuables Transport, Cash Management and Guarding Services	~ 81M €	6,700

Residential Security Services



CONECTADA
CON CENTRAL DE
ALARMAS

PROSEGUR
ACTIVA
902 202 999

PROSEGUR



Residential Security Services 1H 2009 results analysis

In Million Euros

 Total Growth

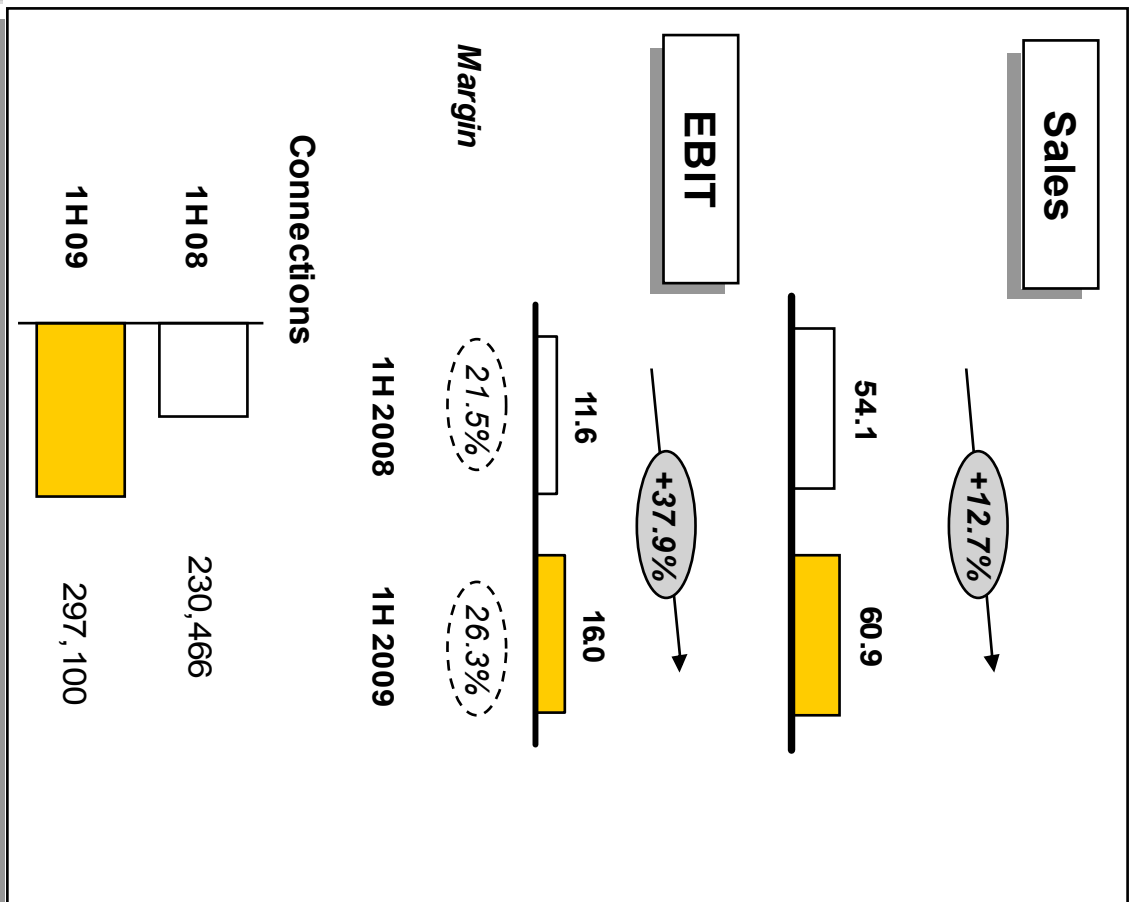

Highlights of the period

- Strong growth in Prosegur Activa's business both in:
 - Connections and sales, including the positive effect from incorporating the Telemergencia business in Chile and Punta Systems in Uruguay
 - And EBIT margins due to the strategy of sustainable growth combined with high profitability
- On June 24th 2009, the Group acquired the 100% of Orus Seguridad Electrónica S.A in Peru. This acquisition means that Prosegur is present in 6 countries



PROSEGUR

